

The Thunder SPARC Processor

HOT Chips VI

August 15-16, 1994

Bruce D. Lightner
Vice President, Development

Metaflow Technologies, Inc.
4250 Executive Square, Suite 300
La Jolla, California 92037
(619) 452-6608
Internet: lightner@metaflow.com

METAFLOW

Metaflow Background

- Company founded in 1987
- Pioneers in out-of-order/speculative execution microprocessor design
- First major design contract was LSI Logic's "Lightning" SPARC chipset (completed 1991)
- "Thunder" SPARC 3-chip set is improved version of "Lightning" 4-chip set
- Project 100% funded by Hyundai Electronics
- Thunder chipset first silicon July 1993
- Patented out-of-order architecture

METAFLOW

Thunder SPARC Mbus Module

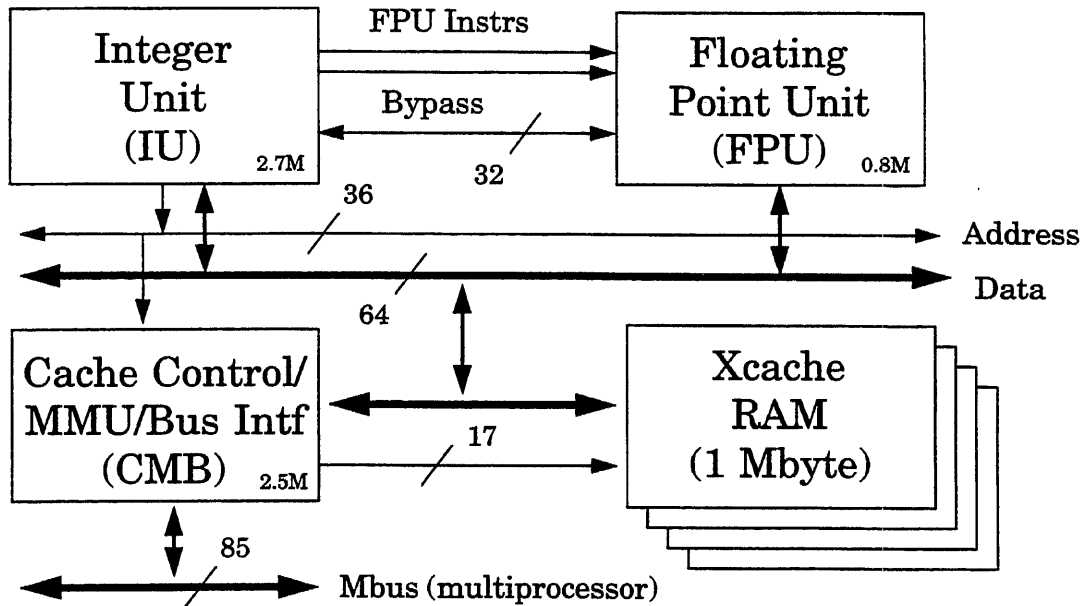

METAFLW

Thunder SPARC Chipset

- Superscalar fetch, issue, and execution
- Dynamic scheduling (dataflow)
- Out-of-order execution
- Speculative execution
- Above “hidden” from the programmer
- Factor of 2-3 performance advantage from architecture

METAFLW

Microprocessor Hardware Trends

- Superscalar instruction issue
- Super-pipelined execution units
- Super-fast processor clocks (>100 MHz)
- Out-of-order execution
- Speculative execution

METAFLOW

Out-of-Order Execution

PROGRAM ORDER

COMPLETION ORDER

```
float A, X, XX, X1
```

```
int n
```

```
.
```

```
.
```

```
.
```

```
X1 = 1 / A;
```

```
XX = A * A;
```

```
n = n + 1;
```

```
X = X + A;
```

```
.
```

```
.
```

```
.
```

```
.
```

```
.
```

```
.
```

```
n = n + 1;
```

```
X = X + A;
```

```
XX = A * A;
```

```
X1 = 1 / A;
```

```
.
```

```
.
```

```
.
```

<u>Operation</u>	<u>Clocks</u>
FP divide	10
FP multiply	5
FP add	3
Integer add	1

METAFLOW

Speculative Execution

$$\sum_{i=0}^n \sqrt{X_i}$$

C EXAMPLE

```

for ( i = 0; i < MAX; ++i ) {
  if (X[i] < 0) error_exit();
  sum = sum + sqrt(X[i]);
}

```

Speculative execution opportunity

Speculative execution opportunity

FORTRAN EXAMPLE

```

DO 100 i = 1, max
  IF (X(i) .LT. 0) CALL error_exit
100 CONTINUE

```

METAFLOW

Conventional Pipeline

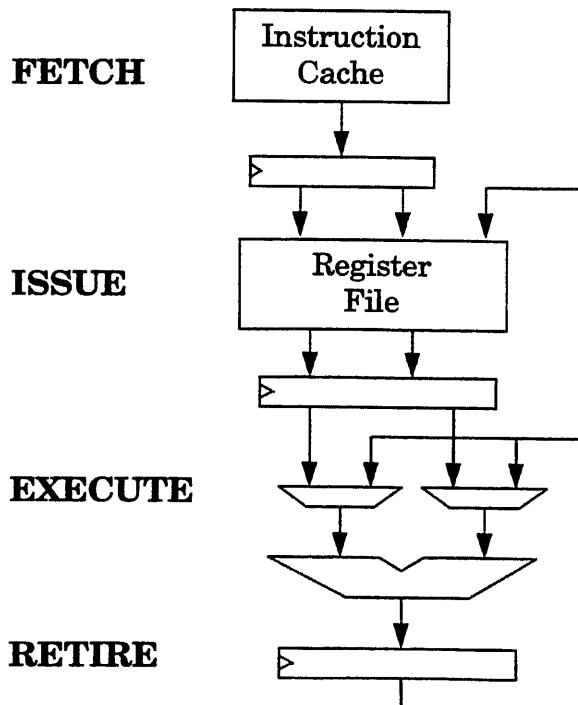

METAFLOW

Metaflow Pipeline (DRIS)

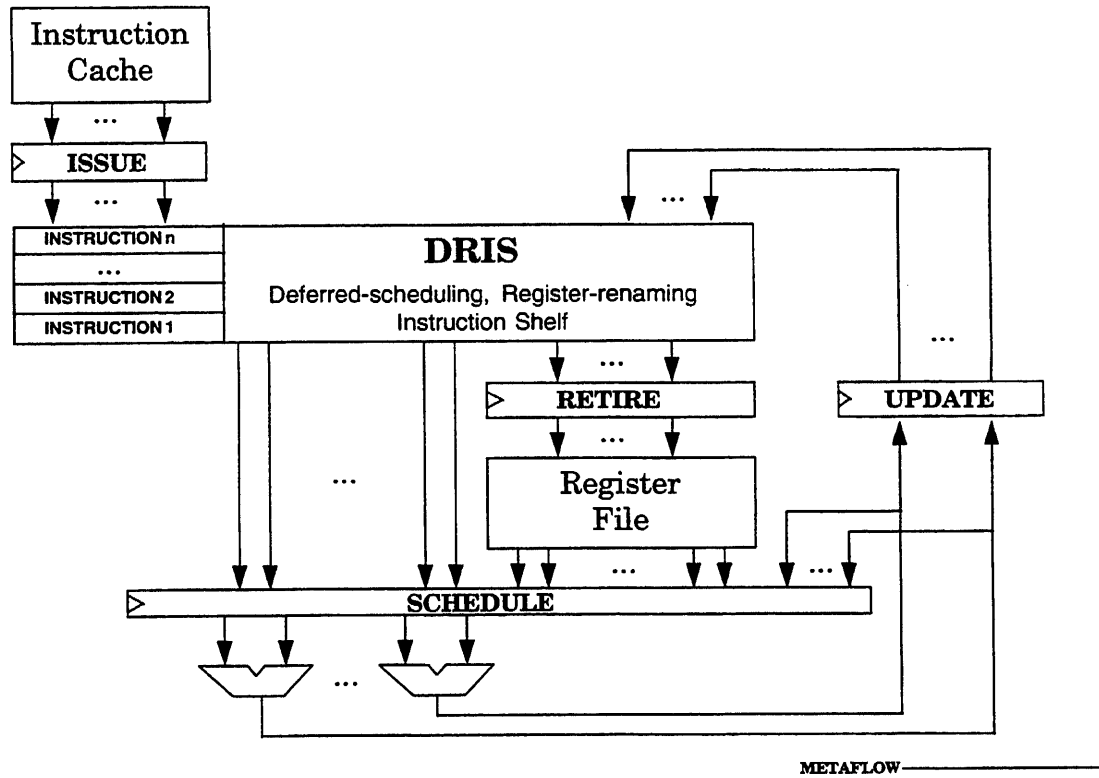

Metaflow DRIS Entry

Source Operand 1

Locked	RegNum	ID
--------	--------	----

Source Operand 2

Locked	RegNum	ID
--------	--------	----

Destination

Latest	RegNum	Instruction's Results
--------	--------	-----------------------

Dispatched

Yes/No

Functional Unit

Class Number

Executed

Yes/No

Program Counter

Content

Thunder IU

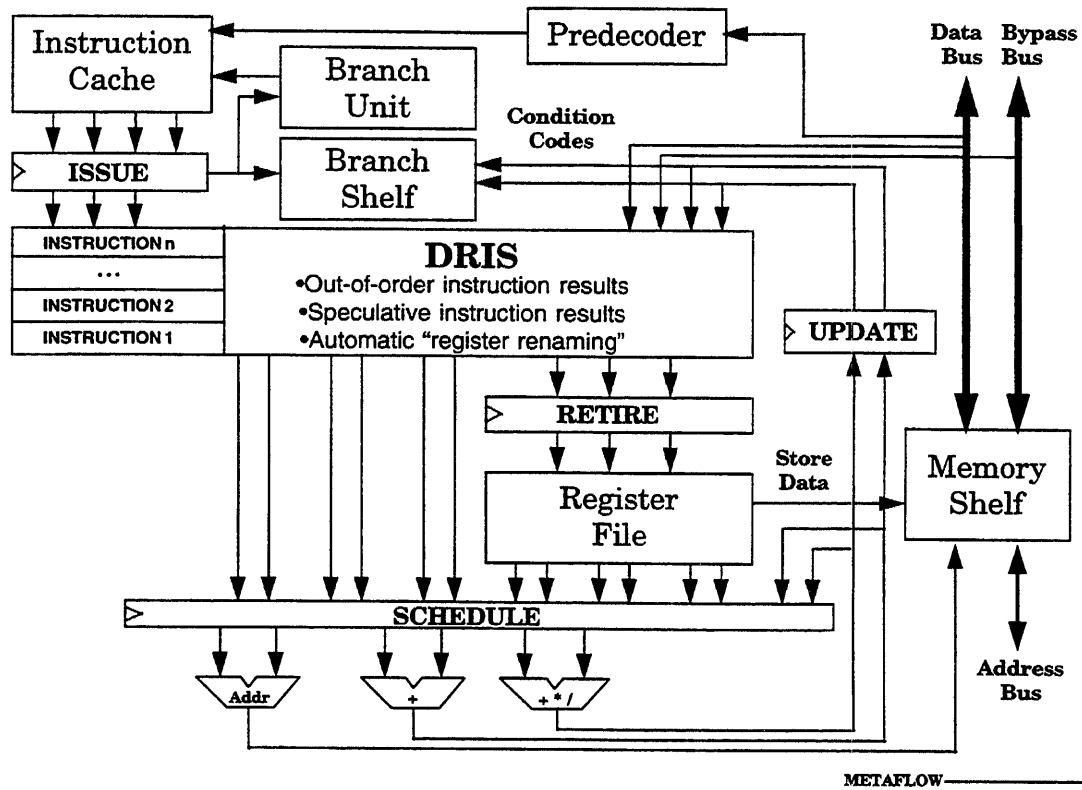

Thunder Processor Distinguishing Features

- 4 instructions issued per clock (3 integer, 2 floating point instructions and one branch)
- 8 parallel functional units (3 integer ALUs, 2 FP ALUs, 1 branch unit, 2 memory/bypass)
- Dataflow-based out-of-order instruction issue/execution (memory/ALU operations), in-order completion, precise traps and interrupts
- Speculative execution beyond unresolved conditional branches (multiple basic blocks with instant state repair on error)
- Above mechanisms transparent to executing program (strict SPARC V8 compatibility)

Thunder Unusual Features

- Eager evaluation (“folds” conditional branches)
- Multiple instances of memory locations (“memory renaming”)
- Out-of-order memory references
 - Multiple simultaneous cache miss processing (“non-blocking cache”)
 - Split address and data memory transactions (memory response re-ordering allowed)
- Speculative memory reads with respect to shared memory coherence restrictions (emulates “strong consistency” model)
- Uninterrupted transitions between user and supervisor modes (traps/interrupts)

METAFLOW

Thunder Unusual Features (continued)

Floating Point Unit (FPU)

- Variable latency FPU (early termination for divide/square root)
- Non-blocking divide and square root (concurrent add/multiply)

Branch Prediction

- Dynamic branch prediction
- Generalized loop count prediction
- Return-from-subroutine (**RET**) “folding”
- Jump-through-register prediction (**JMPL** cache)

METAFLOW

Thunder Status

	Thunder 1.0	Thunder 1.5
First Silicon	July/Nov 1993	Q4 1994
Foundry	VLSI Technologies	
CMOS technology	0.6/0.8 μm	0.5 μm
Metal layers	3	4
Supply voltage	5V	3.6V
Clock rate (processor)	50 MHz	80 MHz
(Mbus)	40 MHz	≤ 60 MHz
Die Size (mm square)	14.5/16.5	9.1/11.8
Package	IPGA (391 pins)	TBGA (600+ pins)
Methodology (data path/RAM)	Full custom	Full custom
(control logic)	Standard cell	Standard cell
(test)	JTAG/full scan	JTAG/full scan
External cache RAM (type)	"Viking"	"Pentium"
(size)	Eight 128K x 9	Eight 64K x 18
Total transistors (3 chips)	~6 million	~6 million

METAFLOW

Thunder Performance Goals

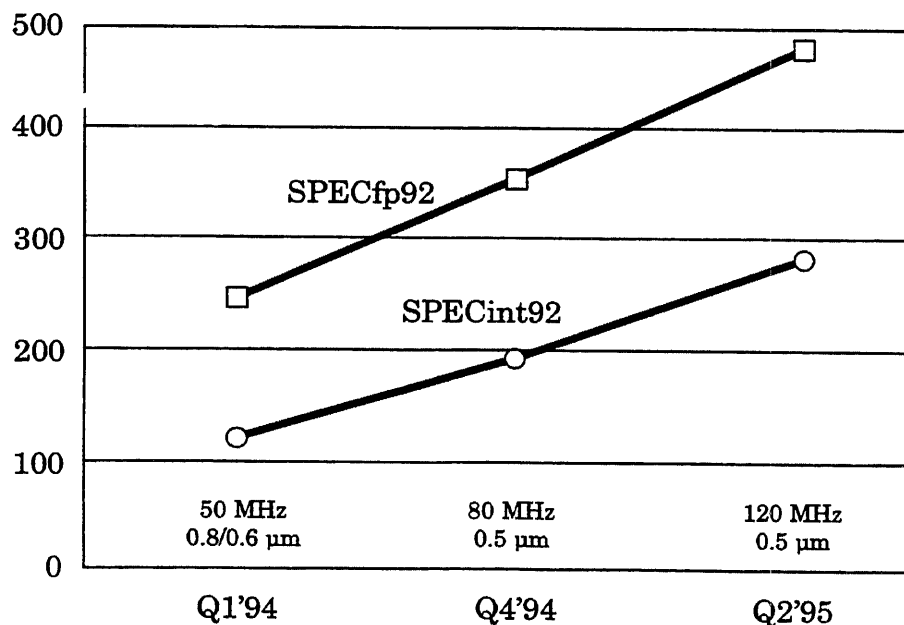

METAFLOW

Thunder 1.0 IU Floor Plan

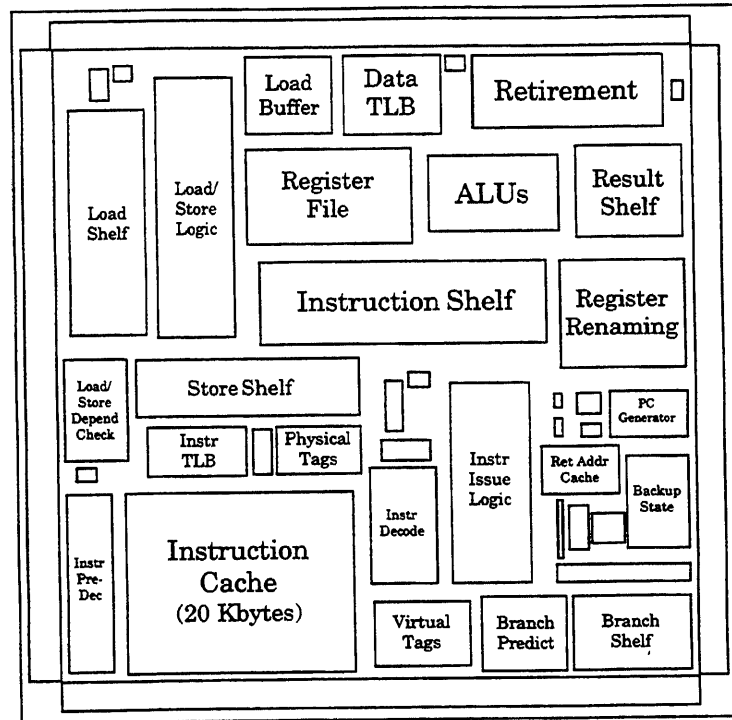

METAFLOW

Thunder 1.0 IU Die Photo

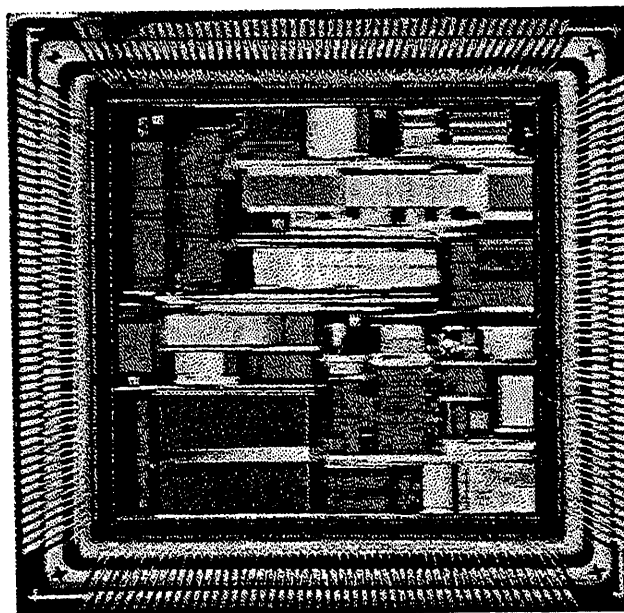

METAFLOW

Thunder 1.0 CMB Die Photo

